

The logo for 'itho' is a blue diamond shape with the word 'itho' written in white lowercase letters. A small orange circle is positioned above the letter 'i'.

itho

CVE ECO 2 Range

System Brochure

Continuous Mechanical Extract Ventilation

Appendix Q Eligible



CVE ECO 2



CVE ECO-fan

Applications

The Itho extractor unit model CVE ECO 2 has been developed for use as a very quiet and energy efficient mechanical extract system for dwellings and light commercial applications.

Applications Include:

- For use in new build family homes
- For use in new build apartment blocks (high-rise buildings)
- Replacing existing extractor units or ventilator boxes
- Improving existing natural ventilation.
- Commercial buildings such as small offices, meeting and waiting rooms.

The CVE ECO 2 is especially suitable for applications where the lowering of energy costs are important.



Product range

CODE	MODEL	Connection to the interior	Connection to the outside air	Capacity	Pressure
110-0036	CVE ECO 2 5 core cable	4 x Ø 125 mm	1 x Ø 125 mm	325 m ³ /h	150 Pa
110-0035	CVE ECO 2 RF	4 x Ø 125 mm	1 x Ø 125 mm	325 m ³ /h	150 Pa
110-0038	CVE ECO 2 HP 5 core cable	4 x Ø 125 mm	1 x Ø 125 mm	425 m ³ /h	150 Pa
110-0037	CVE ECO 2 HP RF	4 x Ø 125 mm	1 x Ø 125 mm	425 m ³ /h	150 Pa

CVE ECO 2



Description

Materials

The extractor units are made of recyclable polypropylene plastic to be more environmentally friendly.

Housing (RAL 7035)

The housing and the fan scroll form a single assembly with the mounting eyes and cable clamps also built-in.

Front Cover (colour RAL 5013)

The front cover closes the case. This extra cover reduces the noise emanating from the motor.

Motor Chassis (colour RAL 7035)

Fitted as standard to the motor chassis are: the motor/fan assembly, electrical components and the power cable.

Motor

The extractor unit has an energy-efficient direct current motor and an impeller with backward curved blades. This configuration means that the fan blades accumulate very little dust or contaminants, ensuring that the efficiency is guaranteed for a longer period than normal.

Settings

The extractor unit has two potentiometers which allow the low and high settings to be adjusted to achieve maximum energy saving. The medium setting is a value which is automatically calculated between the low and high settings.



Adjusting settings

The right to make changes is reserved
9.04 1.3

CVE ECO 2 Range



Four Inlets

To give complete versatility on installation there are inlet spigots on all four sides of the unit. These round inlet spigots have an external diameter of 124 mm.

Outlet and Inlet on one side

To further make installation easier the extractor unit has a (fourth) inlet spigot on the top of the unit next to the exhaust spigot.

Silencer/Airflow Deflector

The silencer's pyramid shape reduces noise and also directs the internal airflow which helps to maximise the performance. The silencer is made from a polyurethane/polyester acoustic foam and is flame retardant according to MVSS 302 and UL94 HF1.

Power Cable and Plug

The unit is equipped as standard with a 1m cable.

Cable Guides

Underneath the unit there are two clips to hold and guide the cable.

Safety

The extractor units meet the requirements for a CE mark.

Fitting and Installation

The CVE ECO 2 can be used in various types of homes, both in new building as well as renovation projects. The unit can be installed in various locations within

the building - for example:

- In the attic
- In a storeroom
- In an airing cupboard

The extractor unit can be installed using the integral mounting eyes - against a wall, on the ceiling and even on sloping surface. We recommend installing the unit against a wall with a density of at least 200 kg/m².

Removal of the Front Cover

The front cover can be removed using a screwdriver. The clasp is on the (left) top side of the cover and the extractor case. The cover can be "pressed open" by horizontally inserting a screwdriver into the clasp. The cover can then be pulled out by hand.



Removing the front cover



Removal of Motor Chassis with Motor/Fan Assembly

There are three slots on the motor chassis. The clamps in the slots are released by inserting a (flat-blade) screwdriver into the motor chassis and pulling the screwdriver handle towards the motor chassis. After the clamps in all three slots have been opened in this way, a lifting strip (at the top right of the chassis) can be used to remove the entire motor chassis, including the motor and fan. .



Removing the motor chassis

Electrical Connection

The standard unit is delivered with 1 metre of 5 core cable attached. The RF version has 1 metre of 3 core cable. Both must be connected to a 230V 50 Hz mains power supply.

Regulation

The capacity of the extractor can be regulated with switches. A number of options are available:

- A three-position switch mode RS-3 connected by wires
- A wireless (RF) three-position switch with a timer function .

Three Position Switch Model

A three-position switch (without an “off” position) can be simply connected using three connecting wires directly to the wall socket (see connection diagram).



Model RS-3 for building in

CVE ECO 2 Range

Wireless (RF) Three-position Switch with Timer Function

The RF versions come complete with an integral receiver and a remote control switch (transmitter).

If required these can be retrofitted into the standard versions by the following method. The receiver must be installed under the cover in the main printed circuit board. The control switch can be placed anywhere in the home and can be used to switch the unit between three settings. More than one remote can be used with each unit and in this instance the most recently used switch determines the setting of the extractor unit.

RF wireless remote control is excellently suited for use in both existing homes and new build as it eliminates the need for costly and messy re-wiring..

Advantages for Existing Buildings

Existing natural ventilation systems can be more easily changed to a mechanical ventilation system because drilling, visible work and electrical wiring are no longer needed.

- It is possible to regulate the system from any room without fitting extra switches later.
- A better interior climate through optimal regulation.

Advantages for New Building Projects

- No wiring needed between the kitchen and the extractor unit
- Regulation from every room is possible and can even be installed later if multiple control switches are used.
- A better interior climate through optimal regulation.

Timer Function

The RF control switch also has an integrated timer. The timer can be activated to keep the ventilation on the high setting for a particular period of time, for example after using the bathroom. The advantage is that the extractor unit switches back to the low



setting after the time expires. This saves energy.

Pressing the timer button once sets the timer for 10 minutes of extraction at the high setting. Pressing the timer button twice sets the timer for 20 minutes. Pressing the timer button three times sets timer for 30 minutes. The time can be cancelled at any time by pressing the 1, 2 or 3 setting buttons.

Installation of the RF Control Switch

The control switch can be installed, for example in the kitchen, by sticking the switch to a tile using the supplied double-sided adhesive tape. It is also possible to attach the switch using screws. Extensive user and installation instructions are supplied together with each control switch.



RF remote control switch



Expanding the Number of Control Switches

Each RF remote control set includes a single receiver for installation in the unit and a single three-position regulation switch (transmitter), which can be used in the kitchen for example. Each receiver can be controlled by several control switches. In other words it is possible to install (extra) control switches in the utility, bathroom, en-suite and toilet.

Range & Frequency

Range of 100 metres in open air. It is not necessary to aim the transmitter and it does not have any external antenna. Transmitter frequency is 868 MHz (no permit is required).

Accessories

Collective Exhaust Duct

If connecting these extractor units to a common riser duct for the individual ventilation of apartments in multi-storey apartment blocks air from the central exhaust duct must always be prevented from flowing back into the apartment. For this purpose, the section between the extractor unit and central chimney duct must close if, for example, the unit is unplugged from the wall socket.

For this purpose Itho can supply the mechanical non-return flap model CVH 125. Further information regarding non-return flaps is available on request.

The right to make changes is reserved
9.04 2.3

CVE ECO 2 Range

Handbooks

A User's Handbook is supplied together with every unit. The handbook contains the following information:

- Information about ventilation in general
- Information about regulation
- Information about maintenance
- Measurement report of values measured on delivery
- Measurement reports of inspection measurements
- Guarantee certificate

Maintenance

The unit must be accessible to allow maintenance and inspection at all times.

The CVE ECO 2 accumulates significantly less dust and grime than standard units and needs to be cleaned only once very four to five years of normal use.

Guarantee

A written two-year guarantee is provided, starting on the date of installation. The guarantee provides for the replacement of the motor/fan assembly free of charge during the guarantee period. The battery of the RF transmitter does not fall under the

guarantee. The guarantee conditions are included in every extractor unit.

Technical Specifications

The minimum (low) and maximum (high) settings of the CVE ECO 2 can be set using the potentiometers situated within the casing. The medium setting is an automatically calculated value and depends on the minimum and maximum capacities set.

	Capacity [m ³ /h]		Pressure [Pa]	Power [W]	Current [A] *
	Standard value	Range			
Setting 1 – Low	75	75-150	8	3.2	0.015
Setting 2 – Medium	150*	150	27	7.5	0.054
Setting 3 – High	225	175-325	100	22.0	0.165
Setting 3 – High	225	175-325	150	28.0	0.210
Setting 3 – Maximum	325	175-325	150	44	0.330

* Setting 2 is a calculated value that depends on the minimum and maximum capacities set.

CVE ECO 2

Capacity qv [l/s]

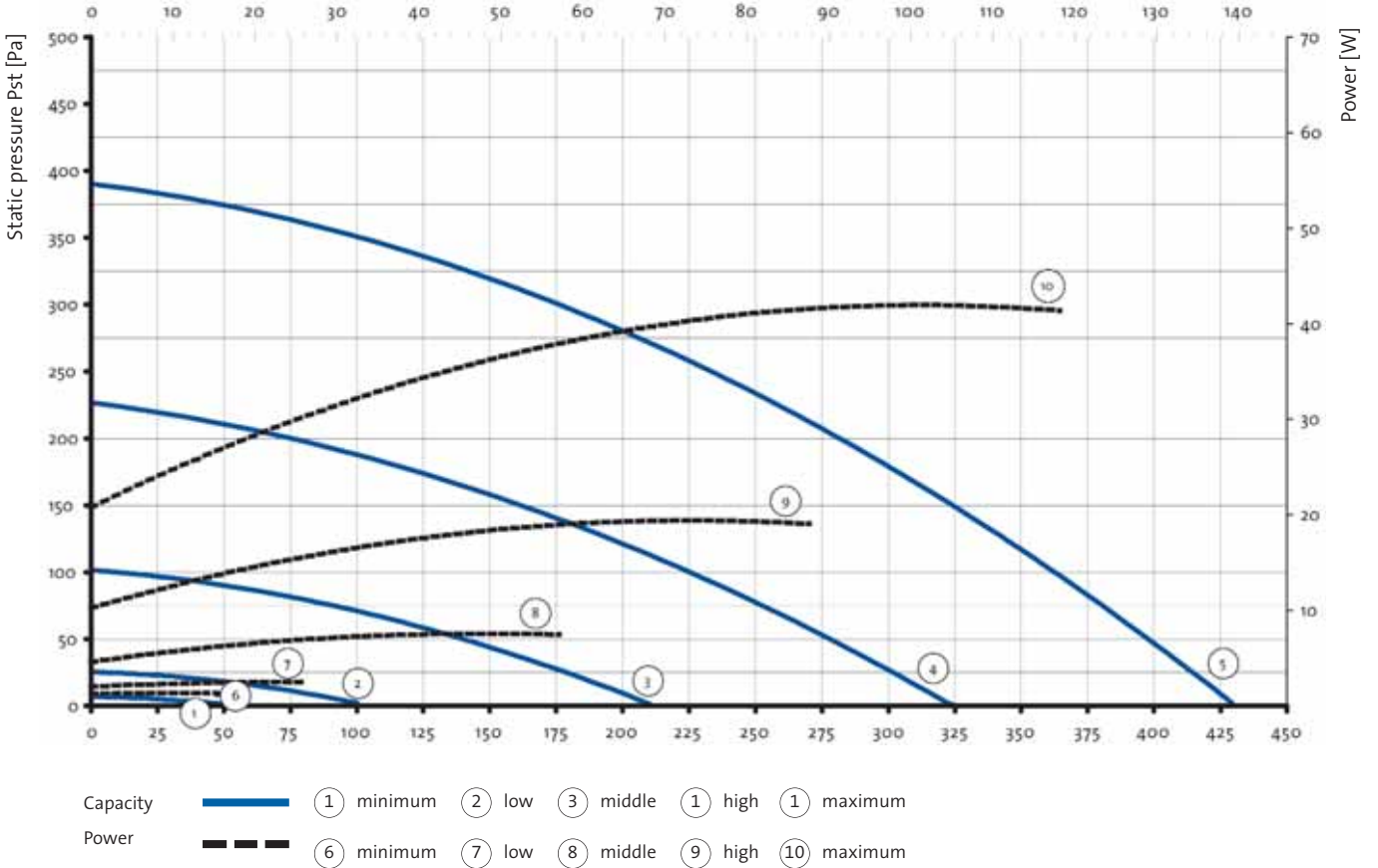

Noise levels Lw(A)

		125 Hz dB(A)	250 Hz dB(A)	500 Hz dB(A)	1000 Hz dB(A)	2000 Hz dB(A)	4000 Hz dB(A)	total dB(A)
Setting 1 radiated	75 m ³ /h / 11 Pa	47.2	35.8	31.7	25.7	20.5	18.3	34.9
Setting 2 radiated	135 m ³ /h / 45 Pa	50.1	42.5	37.9	31.2	25.3	23.5	39.9
Setting 3 radiated	225 m ³ /h / 100 Pa	51.4	49.1	48.5	40.8	37.5	29.1	48.3
Setting 3 max radiated	225 m ³ /h / 150 Pa	57.1	56.0	55.9	36.3	33.2	36.5	54.3
Setting 1 outlet	75 m ³ /h / 11 Pa	42.3	33.3	27.2	23.0	12.5	3.9	30.2
Setting 2 outlet	135 m ³ /h / 45 Pa	50.2	42.9	39.1	31.0	29.5	18.5	40.6
Setting 3 outlet	225 m ³ /h / 100 Pa	54.1	53.2	49.1	40.8	41.8	32.2	50.2
Setting 3 max outlet	225 m ³ /h / 150 Pa	59.1	59.3	55.2	47.3	48.1	39.2	56.4

The right to make changes is reserved 9.04

3.3

CVE ECO 2 HP

Capacity q_v [l/s]

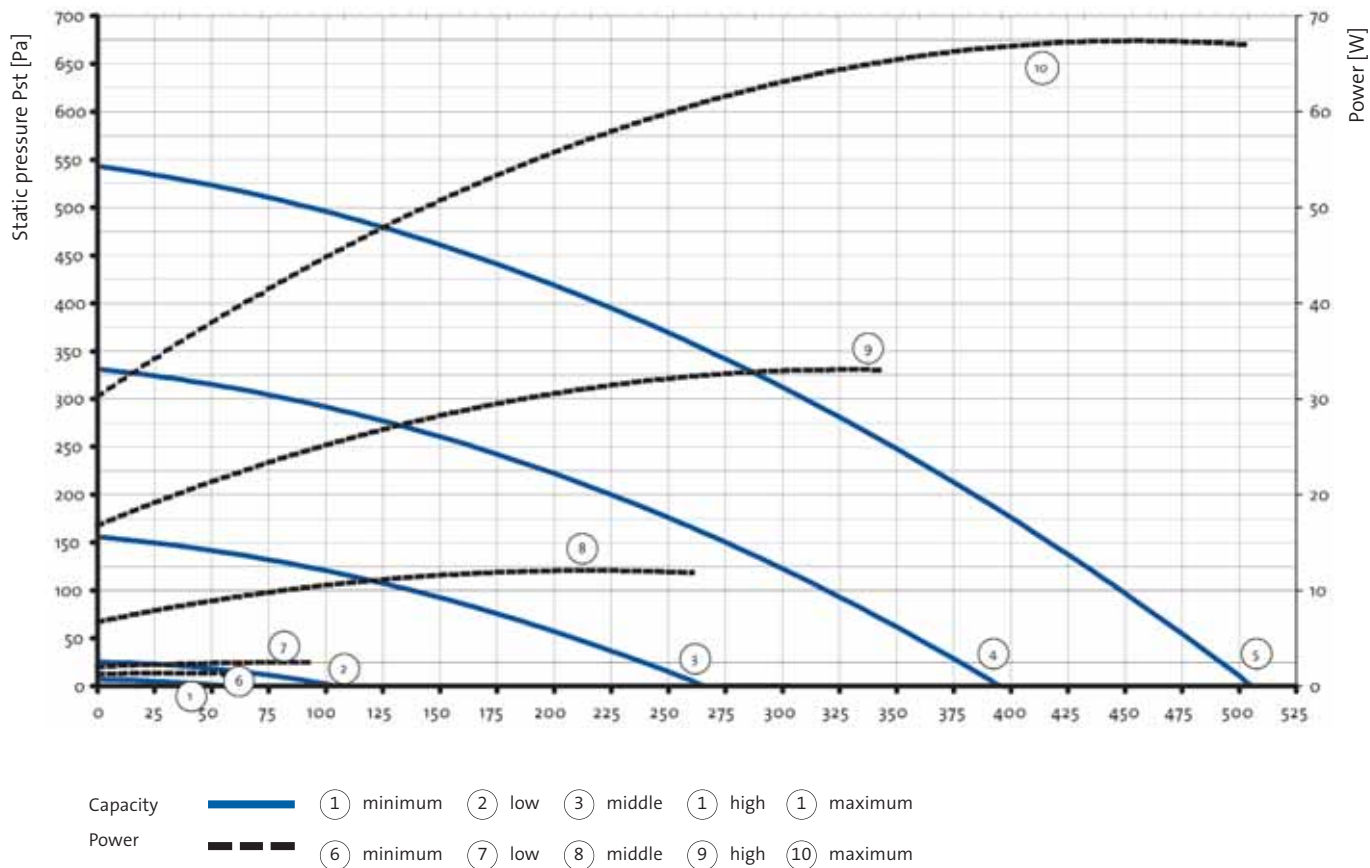

	Capacity [m ³ /h]		Pressure [Pa]	Power [W]	Current [A] *
	Standard value	Range			
Setting 1 – Low	75	75-150	9	3.2	0.012
Setting 2 – Medium	150*	150	27	6.2	0.055
Setting 3 – High	225	175-415	100	19.2	0.157
Setting 3 – High	225	175-415	150	25.2	0.21
Setting 3 – Maximum	415	175-415	150	66.4	0.496

Noise levels Lw(A)

total
dB(A)

Setting 1 radiated	75 m ³ /h / 11 Pa	35.1
Setting 2 radiated	135 m ³ /h / 45 Pa	40.2
Setting 3 radiated	225 m ³ /h / 100 Pa	47.9
Setting 3 max radiated	225 m ³ /h / 150 Pa	51.7
Setting 1 outlet	75 m ³ /h / 11 Pa	30.6
Setting 2 outlet	135 m ³ /h / 45 Pa	40.2
Setting 3 outlet	225 m ³ /h / 100 Pa	50.4
Setting 3 max outlet	225 m ³ /h / 150 Pa	54.3

CVE ECO 2 Range

Connection diagrams

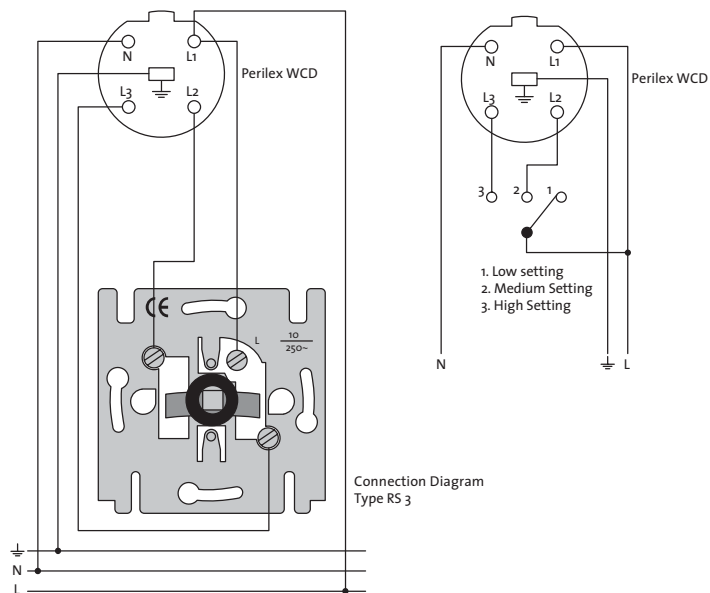

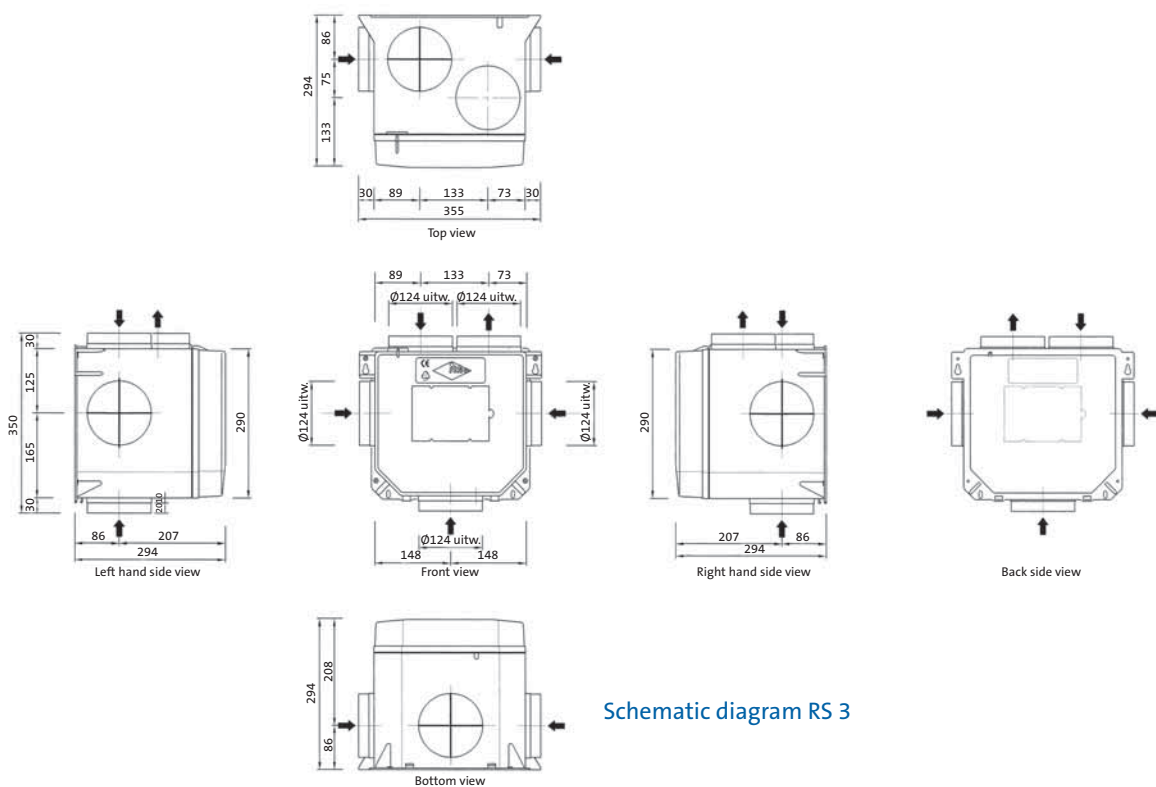

Building Regulations

The 2006 Edition of the UK Building Regulations Approved Document F1: Means of Ventilation (applicable in England and Wales) details four clearly defined systems of ventilation to dwellings. System 3 - Continuous mechanical extract (MEV) is fully complied with by the new CVE ECO 2, a highly efficient and versatile continuous mechanical extract unit.

System 3 - Continuous mechanical extract requires a "minimum high rate" in each wet room to be achieved (Kitchens 13 l/s, utilities and bathrooms 8 l/s, and sanitary accommodation 6 l/s).

In employing this type of system background ventilators must be present in all habitable rooms whilst the air is extracted from all wet rooms.

The "minimum low rate" is calculated by taking the number of bedrooms in the dwelling and applying the l/s value from table 1.1b. In addition, the rate should be no less than 0.3 l/s per m² of internal floor area (all storeys) plus, for each additional occupant over and above the anticipated two for the first bedroom and one for each of the others, a further 4 l/s must be added to the extract rate. No allowance is made for air infiltration.

With its low consumption DC motor, the system provides quiet, uninterrupted extract ventilation from the dwelling removing the contaminated air via all of the "wet" rooms and relying on background ventilators to create a permanent air path through the property from the "dry" habitable rooms.

Available in a total of 6 versions, the CVE ECO 2 is a compact system that ensures regular, controlled, energy efficient ventilation for new build, high and low rise buildings and also renovations.

Building Regulations

Continuous Mechanical Extract Ventillation

- Continuously running whole house ventilation system.
- Extract points located in all wet rooms
- Background vents located in all habitable rooms
- Central system mounted in loft or cupboard and ducted through to wet rooms.

Continuous Extract

- 1 Determine the whole building ventilation rate from **Table 1.1B**
- 2 Calculate the whole dwelling air extract rate (continuous) at maximum operation by adding the “minimum high rate” room rates from **Table 1.1A**

- The required rates are as follows:
Maximum Rate (Boost) is the greater of 1 or 2 (and should be at least the **Table 1.1A** minimum high rate)

- Minimum Rate should be at least the whole building ventilation rate in **Table 1.1B**

Background Ventillation

Controllable background ventilators that have a minimum 2500 mm² equivalent area should be fitted in all habitable rooms. Noisy Sites: Contact Itho Technical Department for advice.

Table 1.1A

Room	Minimum intermittent extract rate		Continuous rate
		Minimum high rate	Minimum low rate
Kitchen	30 l/s (adjacent to hob): or 60 l/s elsewhere	13 l/s	Total extract rate must be at least the whole building ventilation rate in Table 1.1B
Utility room	30 l/s	8 l/s	
Bathroom	15 l/s	8 l/s	
Sanitary Accomodation	6 l/s		

Table 1.1B

Whole building ventillation (l/s)	Number of bedrooms in dwelling				
	1	2	3	4	5
	13	17	21	25	29
Minimum value in any dwelling of 0.3 l/s per m ² floor area (b)					

a. This is based on two occupants in the main bedroom and a single occupant in all other bedrooms. For greater level of occupancy add 4l/s per occupant.

b. This includes each floor, e.g. for a two storey building, the ground and the first floor areas.

SAP Appendix Q Eligible

The CVE ECO 2 is SAP Appendix Q eligible proving it to be one of the most energy efficient MEV units available.

Designed to calculate the energy performance of Dwellings, the Standard Assessment Procedure (SAP) Appendix Q website: www.sap-appendixq.org.uk is a UK based Government led initiative used to demonstrate compliance with building regulations within the following areas - Part L (England and Wales), Section 6 (Scotland) and Part F (Northern Ireland), providing energy ratings for dwellings that can be compared nationally. Below are the relevant independent BRE test results for the CVE ECO 2 and the CVE ECO 2 HP:

As featured in the Energy Saving Trusts' 'Demonstrating Compliance - Best Practice', in order to meet reduced CO2 emission targets, MEV units have been set certain standards and must have a specific fan power (SFP) of 0.6 W/l/s or less. This figure has been both reached and exceeded by the CVE ECO 2 as you can see, a credit to Itho's continued technological advancements.

The Energy Saving Trust's 'Best Practice' standards along with The Code for Sustainable Homes both offer valuable guidance toward sustainable home building and offer the industry the chance to exceed Government targets

Test report – SAP Appendix Q – MEV Test report Number 244-168 Test report issued 03/04/08

Standard Assessment Procedure 2005 – Appendix Q MVHR Product Data

Product tested CVE ECO 2

Results for Appendix Q at minimum flow rate condition

This product has only been tested with rigid ductwork and it is not applicable for SAP Appendix Q if installed with flexible ductwork.

Table Q2 – Systems with rigid ductwork only

Exhaust terminal configuration	Fan speed setting	Total flow rate (l/s)	Specific fan power (l/s)	Energy Saving Trust Best Practice Performance Compliant
Kitchen + 1 additional wet room	100% variable	21.0	0.18	Yes
Kitchen + 2 additional wet rooms	100% variable	29.0	0.17	Yes
Kitchen + 3 additional wet rooms	100% variable	37.0	0.18	Yes
Kitchen + 4 additional wet rooms	100% variable	45.0	0.20	Yes
Kitchen + 5 additional wet rooms	100% variable	53.0	0.22	Yes

These figures must NOT be entered directly into the SAP worksheet or any software. They must be entered into the SAP Q Calculation Spreadsheet.

Test report – SAP Appendix Q – MEV Test report Number 244-173 Test report issued 03/04/08

Standard Assessment Procedure 2005 – Appendix Q MVHR Product Data

Product tested CVE ECO 2 HP

Results for Appendix Q at minimum flow rate condition

This product has only been tested with rigid ductwork and it is not applicable for SAP Appendix Q if installed with flexible ductwork.

Table Q2 – Systems with rigid ductwork only

Exhaust terminal configuration	Fan speed setting	Total flow rate (l/s)	Specific fan power (l/s)	Energy Saving Trust Best Practice Performance Compliant
Kitchen + 1 additional wet room	100% variable	21.0	0.18	Yes
Kitchen + 2 additional wet rooms	100% variable	29.0	0.17	Yes
Kitchen + 3 additional wet rooms	100% variable	37.0	0.18	Yes
Kitchen + 4 additional wet rooms	100% variable	45.0	0.20	Yes
Kitchen + 5 additional wet rooms	100% variable	53.0	0.22	Yes
Kitchen + 6 additional wet rooms	100% variable	61.0	0.27	Yes

These figures must NOT be entered directly into the SAP worksheet or any software. They must be entered into the SAP Q Calculation Spreadsheet.

and to aspire to go that extra mile. Following years of experience in having to meet continually tightening tight demands, Itho always aims to stay one

step ahead and continues to offer ventilation solutions that exceed current expectations.

Free Design Service & Training

Itho's comprehensive design service helps take the stress out of specifying a ventilation system. Offering FREE technical and design assistance for all aspects of mechanical ventilation, simple sketches and scribbled dimensions can be easily converted into a quotation and a professional plan to save you the time and the hassle.

With an in-depth knowledge of current UK Building Regulations (England,



Wales, Scotland & Northern Ireland), all plans are guaranteed to comply with all current legislations especially those of Part B and Part E.

With the ability to both send and receive all plans electronically and manually, this free design service has been specifically developed to help make your life easier.



Within its UK Head Office in Burton on Trent, Itho houses a fully equipped training facility and often runs industry relevant courses for both Specifiers and Installers that help offer a greater understanding of the importance of ventilation.

For those in need of CPD level courses, the following are currently available:

Energy Efficient Ventilation & the future of ventilation systems.
Importance of Installation Practice to Maximise System Performances .

To find out more please forward your request to: info@itho.co.uk

Schiedam Head Office and Factory visits can be arranged for key industry personnel and provide the perfect arena to learn more about Itho's history and their continued drive for improvement.

More comfortable and energy efficient climate system

ITHO demonstrates that...

Wherever you live and work. There is a great chance that almost every day you will come into contact with the products and services of Itho because we develop climate systems for places where people are active. From homes to offices and production areas. From shops & restaurants to sports complexes & hotels. The inhabitants, users and owners of all these buildings always have the same two wishes in the end. On the one hand they want the greatest possible comfort and on the other to use the least amount of energy. These might appear to be conflicting demands but at Itho we have set ourselves the goal of demonstrating that these two can actually go hand-in-hand. We have the professionalism, the enthusiasm and the innovative energy necessary to be able to demonstrate this: with figures, with test results and especially, with satisfied and enthusiastic clients and users.



Itho Ventilation Limited

10 Faraday Court
First Avenue
Centrum 100
Burton on Trent DE14 2WX
T 0870 460 6741 F 0870 460 6742
E info@itho.co.uk | www.itho.co.uk

