

# CVE ECO 2

The SAP Appendix Q eligible Itho CVE ECO 2 has been developed for use as a very quiet and energy efficient mechanical extract system for dwellings and light commercial applications.

## Applications Include:

- For use in new build domestic dwellings
- For use in new build apartment blocks (high-rise buildings)
- Replacing existing extractor units or ventilator boxes
- Improving existing natural ventilation.
- Commercial buildings such as small offices, meeting and waiting rooms.

The CVE ECO 2 is especially suitable for applications where the lowering of energy costs are important.

The CVE ECO 2 is one of the most versatile and efficient Mechanical Extract Ventilation (MEV) products on the market, due to its intelligent design and ultra low consumption DC (direct current) motors, using considerably less energy than conventional MEV systems. Continuously extracting the contaminated damp air from all wet rooms, these compact units ensure regular, controlled, energy efficient ventilation.



## CVE ECO 2 variations available

CODE	MODEL	Connection to the interior	Connection to the outside air	Capacity	Pressure
110-0036	CVE ECO 2 5 core cable	4 x Ø 125 mm	1 x Ø 125 mm	325 m <sup>3</sup> /h	150 Pa
110-0035	CVE ECO 2 RF	4 x Ø 125 mm	1 x Ø 125 mm	325 m <sup>3</sup> /h	150 Pa
110-0038	CVE ECO 2 HP 5 core cable	4 x Ø 125 mm	1 x Ø 125 mm	425 m <sup>3</sup> /h	150 Pa
110-0037	CVE ECO 2 HP RF	4 x Ø 125 mm	1 x Ø 125 mm	425 m <sup>3</sup> /h	150 Pa

# Technical Information

- The CVE ECO 2 is SAP Appendix Q eligible and has a Specific Fan Power as low as 0.17 w/l/s
- The CVE ECO 2 unit is manufactured in recyclable polypropylene and incorporates a pyramid shaped silencer to reduce noise and direct internal airflow for maximum performance.
- The silencer is made from polyurethane/polyester acoustic foam and is flame retardant to MVSS 302 and UL94 HF1 standards.
- Ducting within the dwelling should be 204mm x 60mm modular plastic or 125mm diameter rigid plastic ducting.
- RF transmission range 100m in free air and is possible indoors through two concrete floors.
- Pointing of transmitter towards the fan is not necessary and no need for an external antenna.
- Frequency 868 MHz, no licence required.

The minimum (low) and maximum (high) settings of the CVE ECO 2 can be set using the potentiometers situated within the casing. The medium setting is an automatically calculated value and depends on the minimum and maximum capacities set.

	Capacity [m <sup>3</sup> /h]		Pressure [Pa]	Power [W]	Current [A] *
	Standard value	Range			
Setting 1 – Low	75	75-150	8	3.2	0.015
Setting 2 – Medium	150*	150	27	7.5	0.054
Setting 3 – High	225	175-325	100	22.0	0.165
Setting 3 – High	225	175-325	150	28.0	0.210
Setting 3 – Maximum	325	175-325	150	44	0.330

\* Setting 2 is a calculated value that depends on the minimum and maximum capacities set.

# SAP Appendix Q

The Standard Assessment Procedure (SAP) Appendix Q website, [www.sap-appendixq.org.uk](http://www.sap-appendixq.org.uk), is a UK-based government led initiative for demonstrating compliance with Building Regulations within Part L (England and Wales), Section 6 (Scotland) and Part F (Northern Ireland). See also the Dwelling Energy Assessment Procedure (DEAP) for the Republic of Ireland.

SAP Appendix Q is a database of energy efficient technologies which have been assessed for performance. The results can be input into a SAP assessment submission.

## BRE independent test results for the CVE ECO 2

The Energy Saving Trust's 'Demonstrating Compliance - Best Practice', states that MEV units must have a specific fan power (SFP) of 0.6 W/l/s or less. As this table shows, the CVE ECO 2 and the CVE ECO 2 HP far exceeds this requirement.

Test report – SAP Appendix Q – MEV Test report Number 244-168  
Test report issued 03/04/08

**Standard Assessment Procedure 2005 – Appendix Q MVHR Product Data**

**Product tested** CVE ECO 2

**Results for Appendix Q at minimum flow rate condition**

This product has only been tested with rigid ductwork and it is not applicable for SAP Appendix Q if installed with flexible ductwork.

Table Q2 – Systems with rigid ductwork only

Exhaust terminal configuration	Fan speed setting	Total flow rate (l/s)	Specific fan power (l/s)	Energy Saving Trust Best Practice Performance Compliant
Kitchen + 1 additional wet room	100% variable	21.0	0.18	Yes
Kitchen + 2 additional wet rooms	100% variable	29.0	0.17	Yes
Kitchen + 3 additional wet rooms	100% variable	37.0	0.18	Yes
Kitchen + 4 additional wet rooms	100% variable	45.0	0.20	Yes
Kitchen + 5 additional wet rooms	100% variable	53.0	0.22	Yes

These figures must NOT be entered directly into the SAP worksheet or any software. They must be entered into the SAP Q Calculation Spreadsheet

**bre**

Test report – SAP Appendix Q – MEV Test report Number 244-173  
Test report issued 03/04/08

**Standard Assessment Procedure 2005 – Appendix Q MVHR Product Data**

**Product tested** CVE ECO 2 HP

**Results for Appendix Q at minimum flow rate condition**

This product has only been tested with rigid ductwork and it is not applicable for SAP Appendix Q if installed with flexible ductwork.

Table Q2 – Systems with rigid ductwork only

Exhaust terminal configuration	Fan speed setting	Total flow rate (l/s)	Specific fan power (l/s)	Energy Saving Trust Best Practice Performance Compliant
Kitchen + 1 additional wet room	100% variable	21.0	0.18	Yes
Kitchen + 2 additional wet rooms	100% variable	29.0	0.17	Yes
Kitchen + 3 additional wet rooms	100% variable	37.0	0.18	Yes
Kitchen + 4 additional wet rooms	100% variable	45.0	0.20	Yes
Kitchen + 5 additional wet rooms	100% variable	53.0	0.22	Yes
Kitchen + 6 additional wet rooms	100% variable	61.0	0.27	Yes

These figures must NOT be entered directly into the SAP worksheet or any software. They must be entered into the SAP Q Calculation Spreadsheet

**bre**

## CVE ECO 2 Dimensions

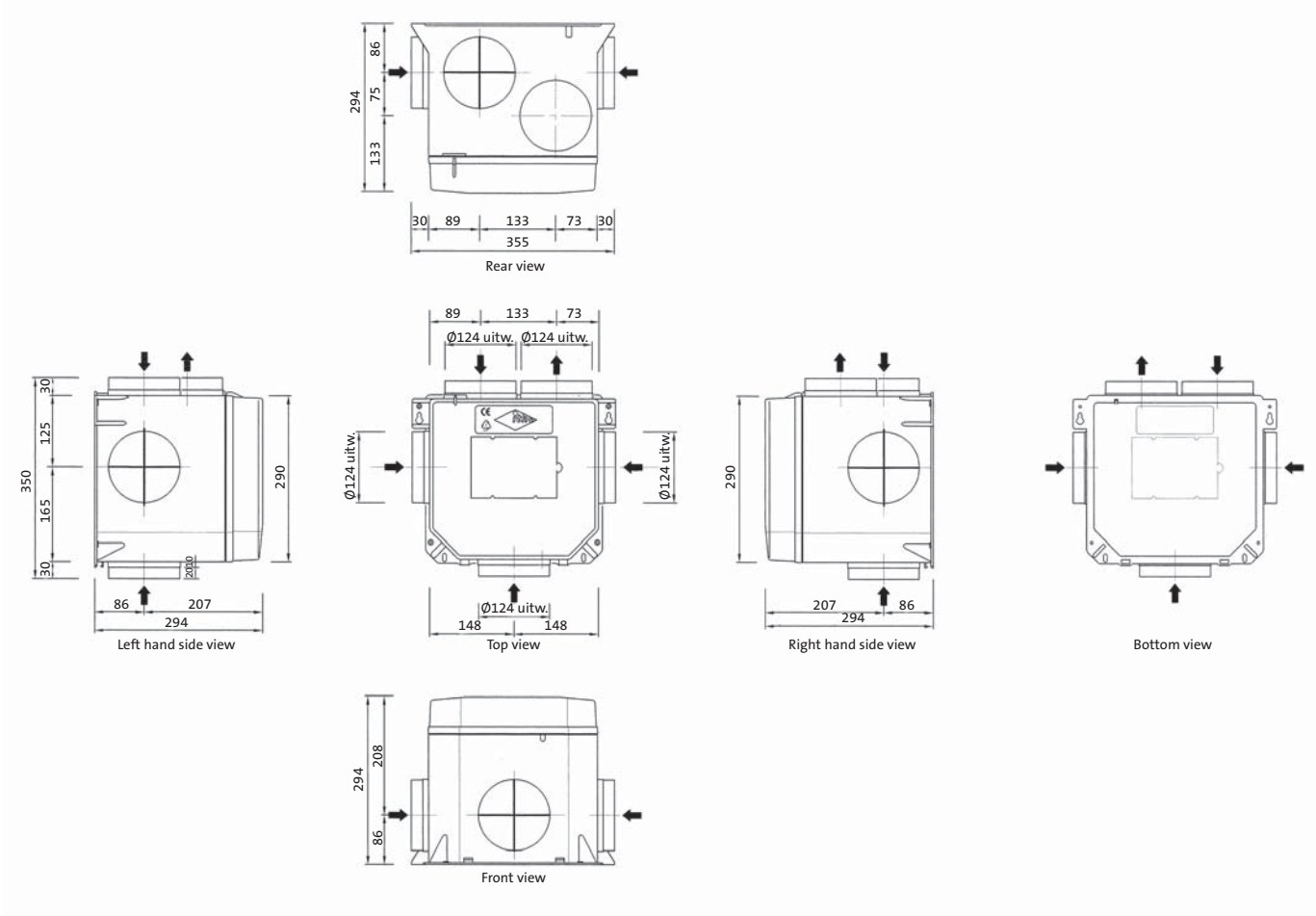

**Itho UK Ltd**  
 10 Faraday Court  
 First Avenue  
 Centrum 100  
 Burton on Trent DE14 2WX  
 T 0845 250 8090  
 F 0845 250 8091  
 E [info@itho.co.uk](mailto:info@itho.co.uk)  
 I [www.itho.co.uk](http://www.itho.co.uk)



Climate for life.